

Dwg. MN4.2.00.50

Model MN4
Version 2.00
2018-Feb-16

C Pemberton-Pigott

Quantity:

1 x 59 mm long, straight ends
1 x 62 mm long, straight ends
2 x 114 mm long, straight ends
2 x 343 mm long, straight ends

1 x 279 mm long, 1 straight end
1 end cut 20 degrees, Left
1 x 279 mm long, 1 straight end
1 end cut 20 degrees, Right

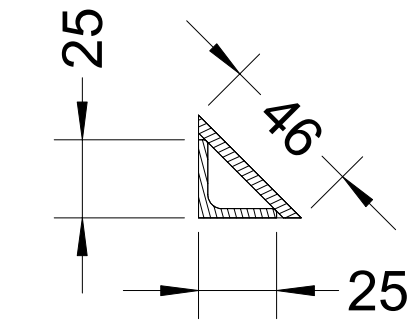

25 x 25 x 3mm Angle Iron
Weld onto 3mm steel, and
cut it flush to make a triangle.

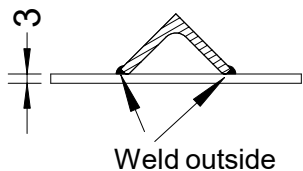

Weld outside

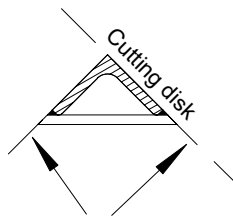

Cut near the joint
and grind flat

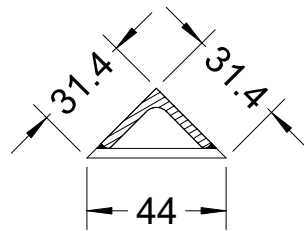

Making inserts